



COMPASS™ CX SERIES

Portable Scales



Energy-Efficient Portable Scale Suitable for Workplace and in-the-Field Weighing

Designed with energy efficiency in mind, the Compass CX series offers a battery life of up to **1,000 continuous hours**, allowing for uninterrupted operation. Featuring a slim, stackable and light-weight design, the CX fits ideally in lab, industrial, education, and even household settings. The streamlined two-button operation means that the balance can be operated easily, and large backlit LCD display enables easy viewing of weighing results.

Standard Features:

- Save money over the lifetime of the balance. Alkaline batteries allow you to maximize operating time with up to 1,000 hours of continuous energy efficient weighing in the workplace or classroom.
- Large backlit display increases readability in low-light conditions and makes it easier to view results from a distance.
- Slim, space-saving design allows for stackable storage for up to four scales.

COMPASS™ CX SERIES Portable Scales

Model	CX221	CX621	CX1201	CX2200	CX5200
Capacity (g)	220	620	1200	2200	5200
Readability (g)	0.1			1	
Span Calibration Mass (Not Included)	200 g	500 g	1 kg		2 kg
Stabilization Time(s)	1.5		2	1.5	
Construction	ABS housing and stainless steel pan				
Calibration	User-selectable external span / Digital with external weight				
Tare Range	Full capacity by subtraction				
Weighing Units*	g, N, oz, lb:oz				
Application Modes	Weighing				
Power Requirement	3 AA batteries (included) or AC adapter (not included)				
Typical Battery Life	1,000 hours				
Display Type	Liquid crystal display (LCD) with backlight				
Display Size	18 mm				
Pan Size (W × D)	128 × 142 mm				
Balance Dimensions (W × D × H)	135 × 201 × 41 mm				
Shipping Dimensions (W × D × H)	170 × 235 × 55 mm				
Net Weight	0.5 kg				
Shipping Weight	0.7 kg				

*Availability is dependent on model.

Other Standard Features and Equipment

ABS housing, slip-resistant feet, stability indicator, mechanical and software overload/underload protection, low battery indicator, auto shut-off

Compliance

- **Product Safety:** IEC/EN 61010-1
- **Electromagnetic Compatibility:** IEC/EN 61326-1 Class B, Basic environments; FCC Part 15 Class B; Canada ICES-003 Class B
- **Compliance Marks:** CE; RCM

Accessories

Carrying Case.....	30467763
Bowl, 1050 mL.....	80850075
Adapter, 5V 1A EU, fixed plug.....	30333866
Adapter, 5V 1A UK, fixed plug.....	30333867

Dimensions

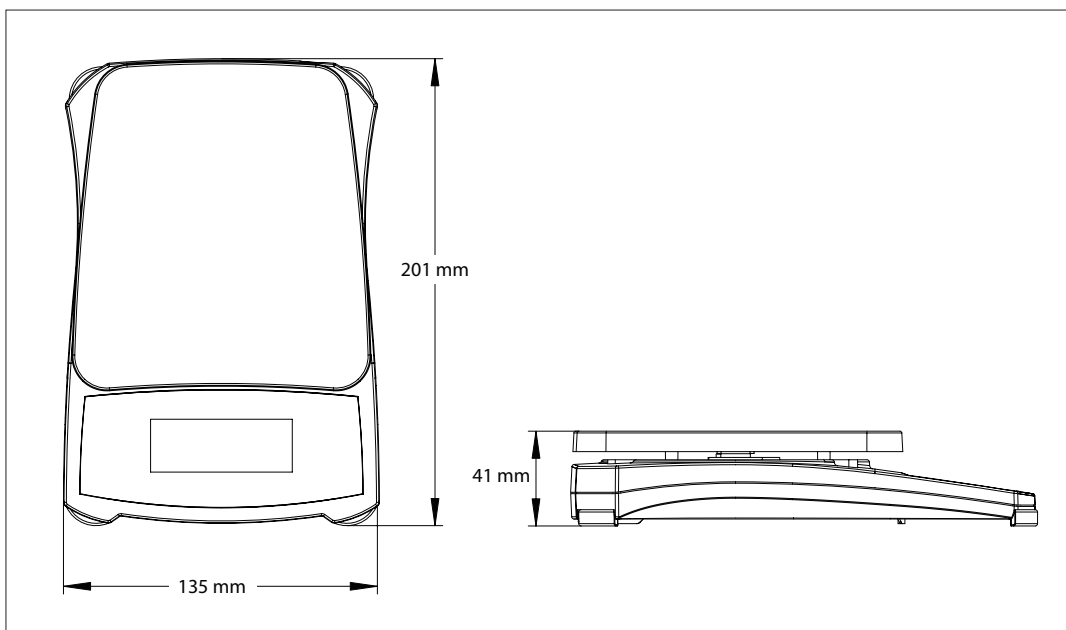

80775680_C 20200324 © Copyright OHAUS Corporation





WolfLabs

Pricing on any accessories shown can be found by keying the part number into the search box on our website.

The specifications listed in this brochure are subject to change by the manufacturer and therefore cannot be guaranteed to be correct. If there are aspects of the specification that must be guaranteed, please provide these to our sales team so that details can be confirmed.

www.wolflabs.co.uk

Tel : 01759 301142

Fax : 01759 301143

sales@wolflabs.co.uk

Please contact us if this literature doesn't answer all your questions.